

ROTARY PISTON

Vacuum Pump

For Hydrogen Seal Oil Purifiers

VACUUM INDUSTRIAL PRODUCTS Model WS-30B Rotary Piston vacuum pump is a heavy duty INDUSTRIAL GRADE unit capable of producing an ultimate vacuum of 10 microns abs (29.9"+ Hg).

The system has been EXCLUSIVELY DESIGNED for use in the power generating industry to distill off condensed water vapor out of generator turbine oil. The motor and solenoid valve are explosion-proof rated and an inline gear reducer is used to address safety concerns for the presence of hydrogen in the process gas stream.

Low pump rpm (350 rpm) and generous oil supply insures minimal wear to the pump from water diluted oil resulting in an exceptionally durable vacuum pumping system. One can easily expect 20+ years of use from this pumping system with only a minimal of routine maintenance required.

FEATURES

- Air Cooled / Water Cooled
- No metal to metal contact
- Long lasting & durable
- Full pumping speed down to 1 Torr
- Absolute pressures to 0.050 Torr
- Over 40 years of proven reliability



SPECIFICATIONS

Pump Model		WS-30B
Displacement	CFM	45
Ultimate Vacuum	Torr	0.010 (29.9"+Hg)
Motor	Hp	3
Pump Speed	RPM	361
Oil Capacity	Gal	3.75
Inlet connection	in.	1.5" NPT
Exhaust connection	in.	2" NPT
Pump Weight	Lbs.	750

VACUUM INDUSTRIAL PRODUCTS 21694 Oak Lane Maple Park IL. 60151

Phone: (630) 357-7700 Fax: (630) 357-7721 www.vipvacuum.com

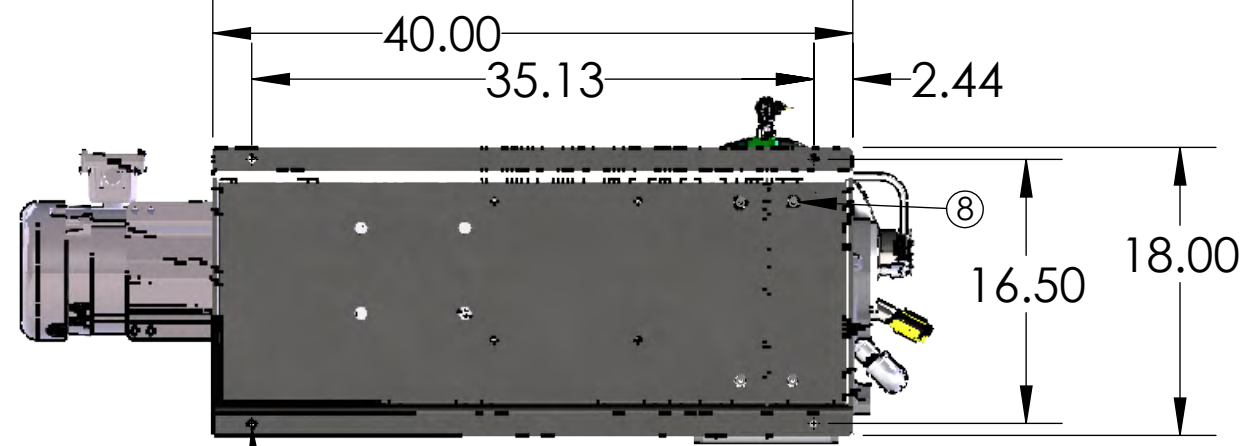
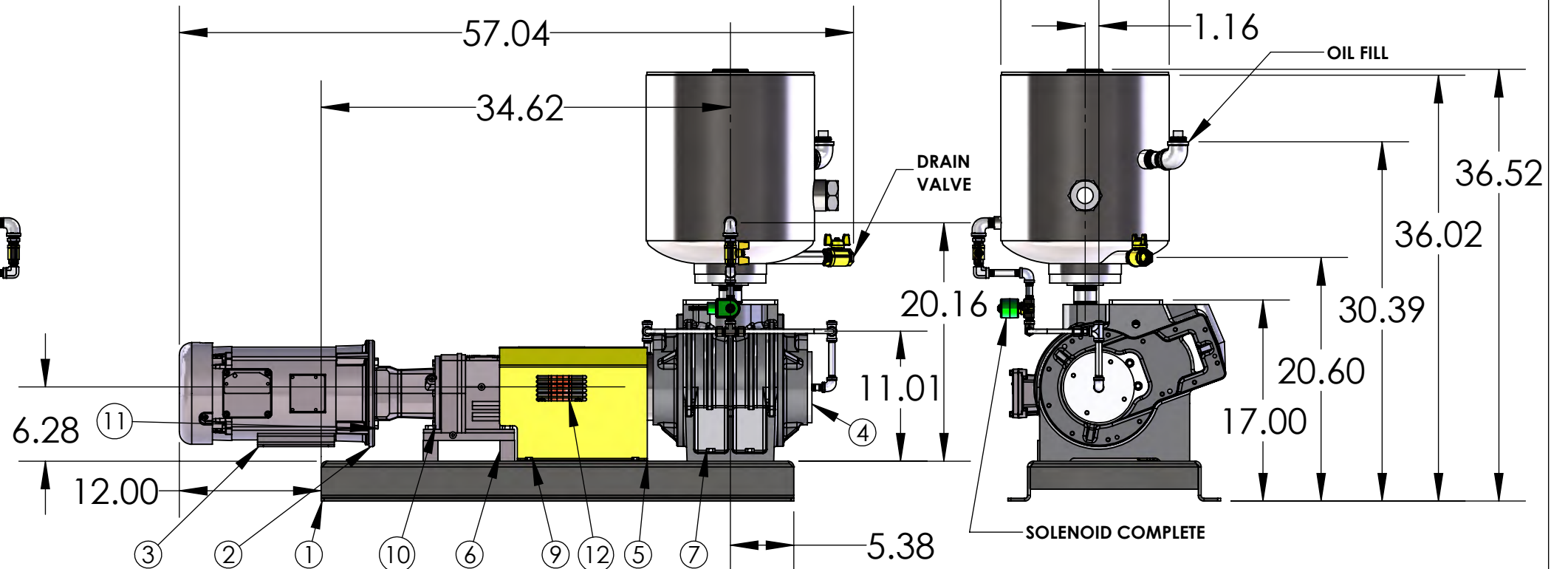
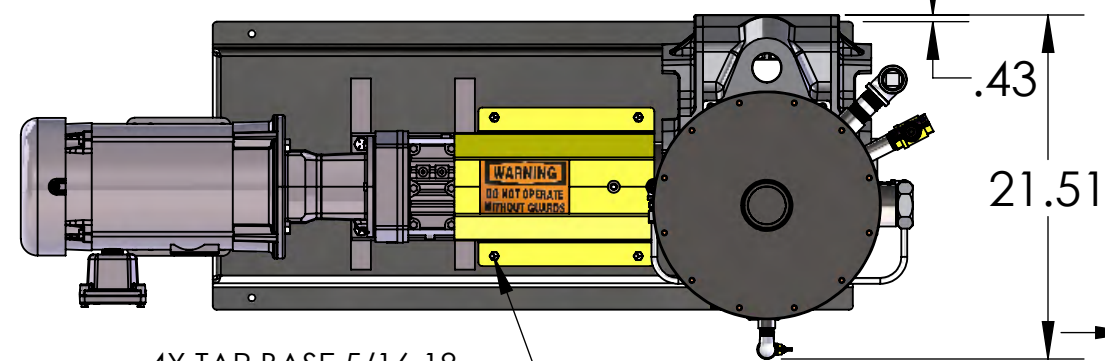
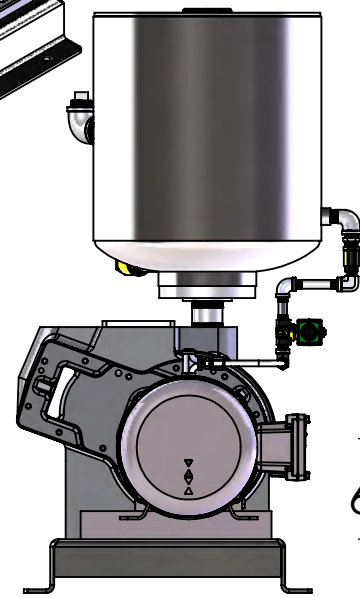
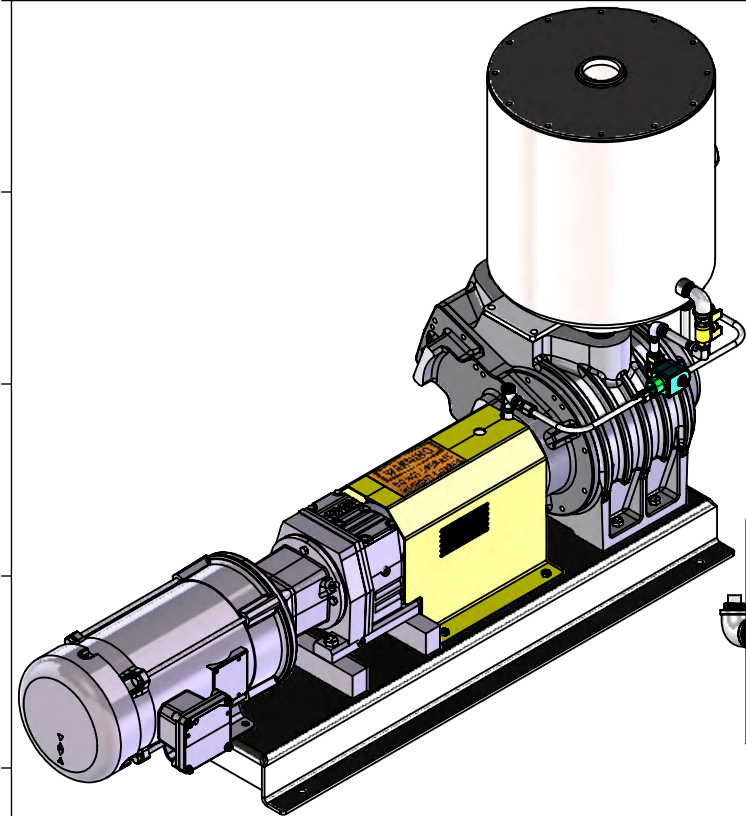

ITEM NO.	PART NUMBER	DESCRIPTION	QTY.
1	SU7020-1	WS303 Base	1
2	SEW Eurodrive R47_AM182	Gearbox	1
3	Baldor CEM7042T	3HP Motor	1
4	WS30B Vacuum Pump	VACUUM PUMP ASSY	1
5	SU7020-3	Coupling Guard	1
6	SU7020-4	Riser	2
7	92865A673	7/16-14 x 1-1/2"lg HHCS	4
8	95462A032	7/16-14 Hex Nut	4
9	92965A581	5/16-18 x 3/4lg HHCS	4
10	92865A716	1/2-13 x 1-1/2"lg HHCS	8
11	92865A256	1/2-13 x 1-1/8"lg HHCS	4
12	Coupling	Max Dynamic D5/ Omega Style E5	1

Tolerance Unless Otherwise Specified
 Fraction = ±.030"
 .X = ±.030"
 .XX = ±.010"
 .XXX = ±.005"
 .XXXX = ±.001"
 Angular = ±1/8°
 Surface = 125Ra

Threads Class 2A & 2B
 Remove Burrs and Sharp Edges
 .015" Maximum

Material:
SEE BOM

Rev	Description	By	Approved	Date
Vacuum Industrial Products 21694 Oak Lane Maple Park, IL 60151 PH 630 357-7700 www.vipvacuum.com				
Description: VACUUM PUMP ASSY		Part / Drawing Number: SU7020		Rev: R0.0
Notice: This drawing and the principles and elements of design embodied therein are the exclusive property of Vacuum Industrial Products and are not to be communicated, disclosed, reproduced or used except as previously authorized in writing by said company.		Size: B (11x17)		
Drawn By: Jason S. Date: 12/28/2020		Approved By: Rade T. Date: 12/28/2020		